

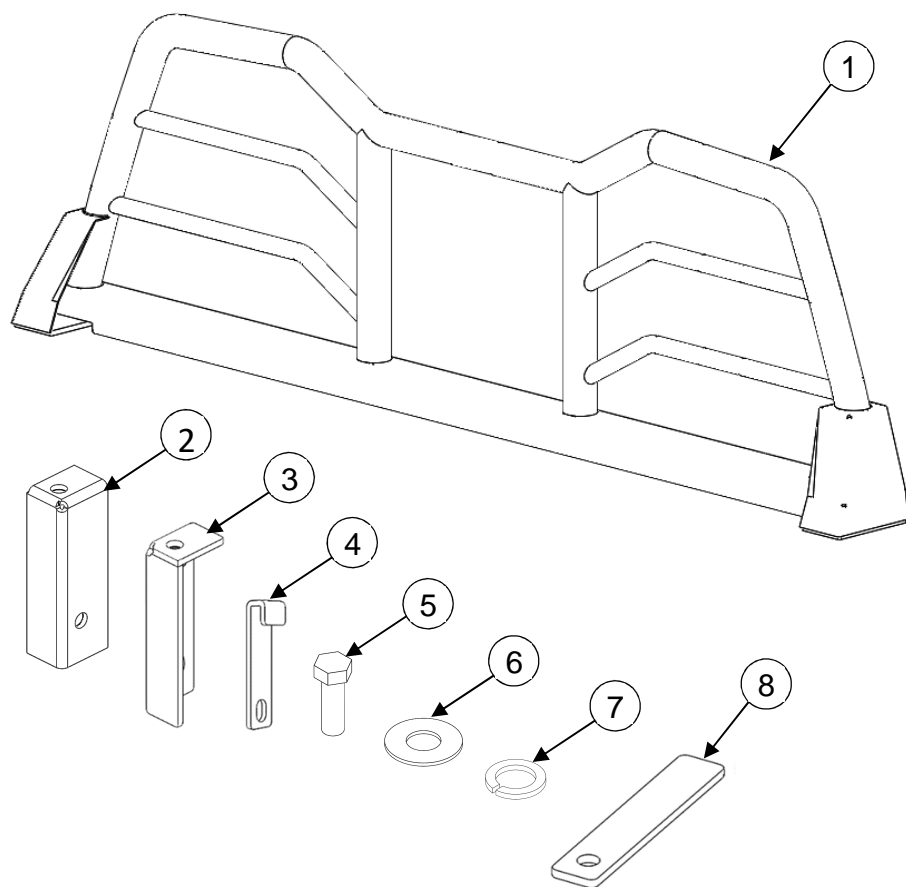

Cab Protector

Ram 1500 (2018+)

www.mopar.com



TOOLS REQUIRED

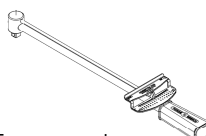

Torque wrench

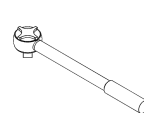

Ratchet



Ratchet extension



19mm Socket

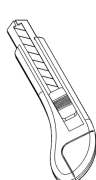

Cutter knife

Call Out	Description	Quantity	Service Part (Y/N)	Part Number
1	Cab protector rack	1	N	82215495AC
2	Driver main bracket L	1		822154950BAL
3	Passenger main bracket R	1		822154950BAR
4	Auxiliary bracket	2		822154954BA
5	1/2 x 2" Hex head bolt	4		AST-T131
6	1/2" Flat washer	4		AST-RP38
7	1/2" Lock washer	4		AST-RPR23
8	Foam gasket	2		ASH-E173

NOTE: It's suggested to install with 2 peoples and/or usage of a crane.

Beginning with driver side. Set blade depth on safety knife no deeper than 3mm or blade could scratch paint.

Carefully cut out plastic rectangle along mold line. Stake pocket should be now open.

1

Remove liner of foam gasket.

Stick to the bracket.

2

Thread bolt.

Insert driver main bracket

3

Assemble prior to install.

Attach auxiliary bracket (3) to main bracket (2).

4

Make sure top face of main bracket is flush with plastic bed rail protector.

5

Unscrew the bolt. Place Cab Protector.

6

Attach Cab Protector.

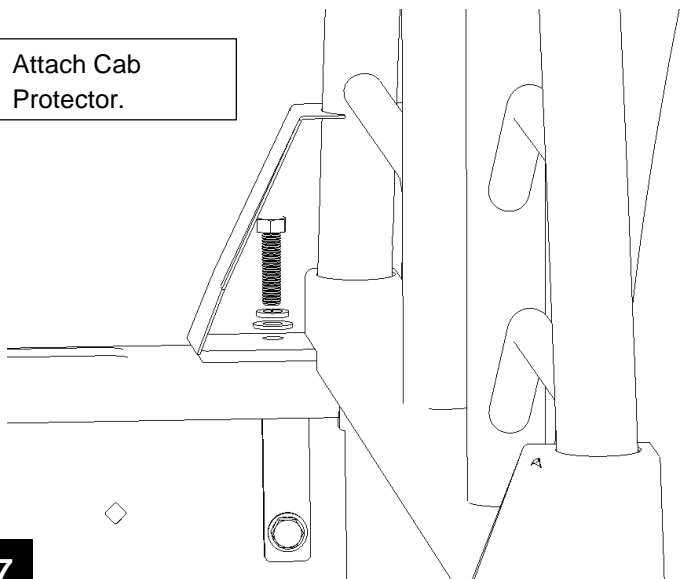

7

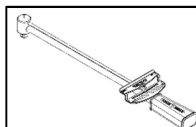

Check alignment and tighten. Torque to 74.5Nm (55 Lb Ft).

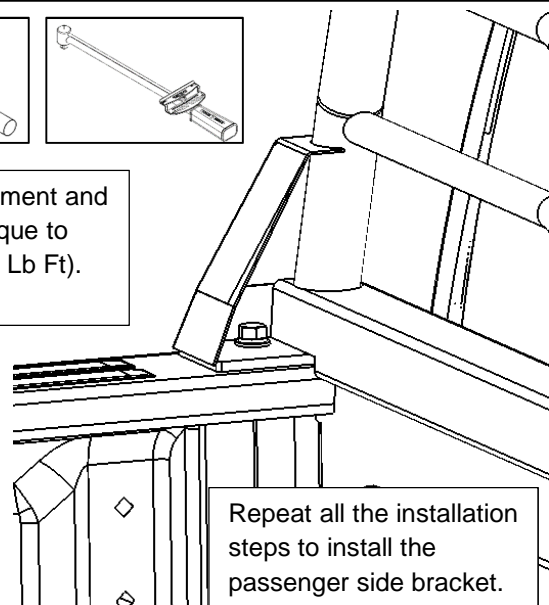

8

Repeat all the installation steps to install the passenger side bracket.

Document Revision History

Date	Section	Summary of Changes Made	Notes
07-24-2017		Initial release.	
05-08-2018		Include notes step 2 and 3.	
08-23-2018		Changed Cab Protector Rack Part Number	
10-12-2018		Changed Cab Protector Rack Part Number	